

SOUDAFLEX 280

Direct Glazing & Bonding Adhesive

Technical Data:

Chemical nature	Polyurethane
Density [g/cc]	1,19 ± 0,02
Colour	Black
Curing mechanism	Moisture-curing
Tack-free time [min] (23°C and 50% r.h.)	35
Shore A hardness	60 [N/mm ²]
Elastic modulus at 100% (ISO 37 DIN 52445)	≥ 2,0 [N/mm ²]
Tensile strength (ISO 37 DIN 53504)	9,0 [N/mm ²]
Elongation (ISO 37 DIN 53504)	≥ 500%
Curing time (at 23° C and 50% r.h.)	> 3 [mm/24h]
Application temperature	From +5°C to +40°C
Temperature Resistance	- 40°C / +100°C, with brief points at +120°C

(*) these values may vary depending on environmental factors such as temperature, moisture, type and size of substrates

Product:

Soudaflex 280 has been specially developed for Indian subtropical conditions after a decade of research, practical application understanding of Indian climate, it is most suitable in high temperatures and extreme humid conditions.

Soudaflex 280 is an excellent non-sag, one-component, flexible and high performance adhesive based on polyurethane technology to be used along with Universal Primer 175 for direct glazing of Glass onto Metal/FRP Frames, Metal to Metal & Metal to FRP.

Characteristics:

- One-component polyurethane adhesive/sealant
- Odorless
- Fast curing time
- Suitable for cold weather applications
- Excellent workability
- High viscosity, high initial tack & non sag properties
- Short cut-off string
- Suitable for use with integral aerials
- Suitable for manual & pneumatic application guns
- Prevents contact corrosion in aluminum body vehicles
- Ageing and weathering resistance
- High UV resistance and colour stable

Remark: The directives contained in this documentation are the result of our experiments and of our experience and have been submitted in good faith. Because of the diversity of the materials and substrates and the great number of possible applications which are out of our control, we cannot accept any responsibility for the results obtained. In every case it is recommended to carry out preliminary experiments.





SOUDAFLEX 280

Direct Glazing & Bonding Adhesive

Application:

Direct glazing of front & rear windshield in Trucks, Earth Moving Equipments, Tractors, Forklifts, Bus & Coach, Repair, Auto After Market, Metro, Railway, Defense, Aviation, Marine and various other commercial and industry specific vehicles.

Suitable for structural bonding of various engineering materials which are subjected to high thermal and dynamic stress in the Transportation Industry. e.g. GI to GI, GI to Al, Steel to Steel, Steel to FRP.

Surface Preparation:

The surfaces to be treated should be perfectly clean, dry and free from dust, oil and grease. It is necessary to apply Soudal Universal Cleaner 165 on glass.

The adhesion on normal vehicle varnishes generally does not require the use of Soudal Universal Primer 175. It is advisable to carry out preliminary adhesion tests on the support. Specific guidance regarding the use of Primers may be obtained by submitting substrate samples to our laboratory.

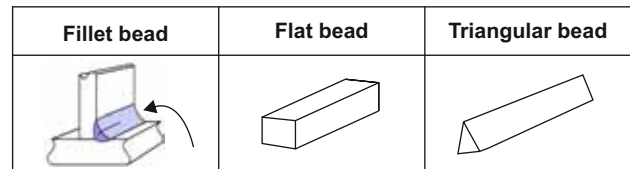

Packaging & Colour:

Colour: Black

Packaging: 600ml sausage

Storage/Shelf Life:

The storage and application of PU sealant affects the shelf life and usage. The shelf life is 12 months from the date of manufacturing if kept in the temperatures from 5°C to 35°C.

General chart for bead size for various parts:		
Location	Type of bead	Dimension of bead
Windows: 3 sides (not at the bottom)	Flat bead	6 mm
Roof top joints	Flat bead	10 mm
Wheel arches	Fillet	6-8 mm
Tail lamps	Fillet	4-6 mm
Internal or interior panel joints or gaps	Fillet	8-10 mm
Between the structure and inner panels before window fitment	Fillet	8-10 mm
Glass pasting/bonding	Triangular	8-10 mm

Remark: The directives contained in this documentation are the result of our experiments and of our experience and have been submitted in good faith. Because of the diversity of the materials and substrates and the great number of possible applications which are out of our control, we cannot accept any responsibility for the results obtained. In every case it is recommended to carry out preliminary experiments.





SOUDAFLEX 280

Direct Glazing & Bonding Adhesive

Product User Guidelines for Best Result:

Step 1: (Glass surface preparation)

- Clean the glass with lint free cloth.
- Remove foam spacer from the glass.
- Clean the glass & adhesive marks of spacers with the help of the Soudal Universal Cleaner 165 cum surface activator.
- Apply Soudal Universal Primer 175 on border area (please refer check list for more detail).



Instructions:

- Shake the bottle of primer for homogeneous mixing of the primer before application.
- Ensure that the bonding agent (primer) has not exceeded expiry date mentioned on the container/tube.

Step 2:

- Remove the foreign particle (like paint, dust) from the frame of the bus.



Step 3:

- Apply grinder to make surface even.



Step 4:

- Apply Soudal Universal Cleaner 165 cum surface activator.



Step 5:

- Apply Soudal Universal Primer 175 (note shake bottle well till the steel ball inside container is clearly audible, for more detail see check list).



Application:

- Place the sausage in the application gun and snip off the closure clip. Cut off the tip of the nozzle to give desired adhesive bead geometry. For satisfactory results the adhesive must be applied with a hand operated cartridge gun, piston-type compressed-air gun or pump operated bulk dispensing equipment. To ensure a uniform thickness of adhesive bead, we recommend that the adhesive be applied in the form of a triangular bead.

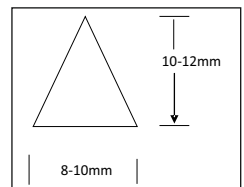

Step 6:

- Make bead in triangular shape keep pneumatic pressure at 6 bar.



Step 7:

- Put spacers of shore A hardness 45-50 to rest the glass.



Remark: The directives contained in this documentation are the result of our experiments and of our experience and have been submitted in good faith. Because of the diversity of the materials and substrates and the great number of possible applications which are out of our control, we cannot accept any responsibility for the results obtained. In every case it is recommended to carry out preliminary experiments.



SOUDAFLEX 280

Direct Glazing & Bonding Adhesive

Step 8:

- Hold the glass with the help of clamp for 8 hours for bonding of glass.



Step 14:

- Finishing – apply low concentration soapy water for finishing.



Step 9:

- Remove excess adhesive from the edges for better finish.



Final Result :

- Best finishing with Soudaflex 280 Direct Glazing Sealant.



Step 10:

- Masking for finishing (use fine line masking tape for better edge finish).



Chemical resistance :

Long term resistance to fresh water, seawater, acid rains, lime water, dilute acids and aqueous cleaners. Short terms- resistance to petrol, grease, mineral oil. Not resistant – to organic acids, concentrated mineral acid, caustic solution or solvent. This information is offered for general guidance only. Advice for specific applications will be issued after consultation.

Step 11:

- Fill the gap with the desired thickness (see check list for pneumatic gun use instructions).



On site test procedure for sealant behavior during climate change:

Skin formation time test:

Indian sub continent is a land of climate diversity. Skin formation time varies from region to region depending on the climate. It is advised to the user to check the skin formation time during climate variations.



Step 12:

- Do tooling before skin formation time with appropriate spatula.



This helps the end user in deciding tooling time for the finishing of the beads.



Step 13:

- De masking – remove the tape carefully without touching painted surface before the sealant skins over.



Skin formation time is the time consumed at which the sealant do not stick to the finger.

(see figure no. 3)



Remark: The directives contained in this documentation are the result of our experiments and of our experience and have been submitted in good faith. Because of the diversity of the materials and substrates and the great number of possible applications which are out of our control, we cannot accept any responsibility for the results obtained. In every case it is recommended to carry out preliminary experiments.





SOUDAFLEX 280

Direct Glazing & Bonding Adhesive

Cure mechanism::

Soudaflex 280 cures by reaction with atmospheric moisture. Due to variation of the moisture contents the curing rate changes (see diagram). In ideal condition curing rate is 4mm/24 hrs.

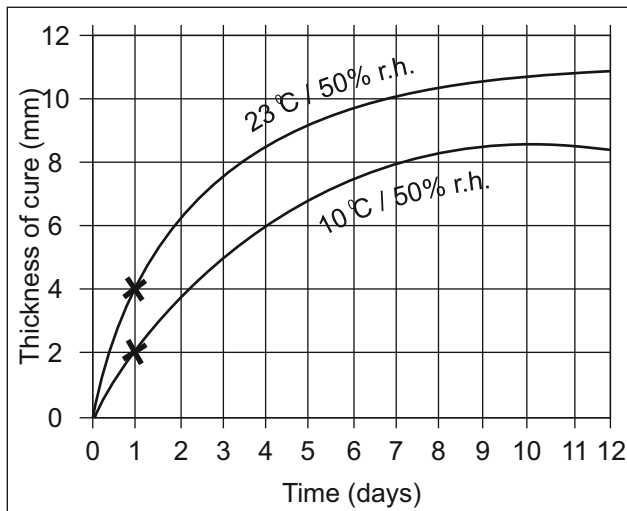

Lap Shear Test:

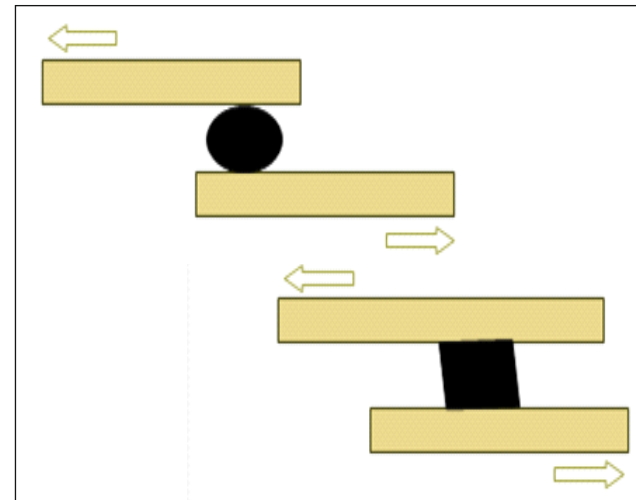

Peel Test:

Peel test is recommended to test periodically to ensure application sequence consistency.

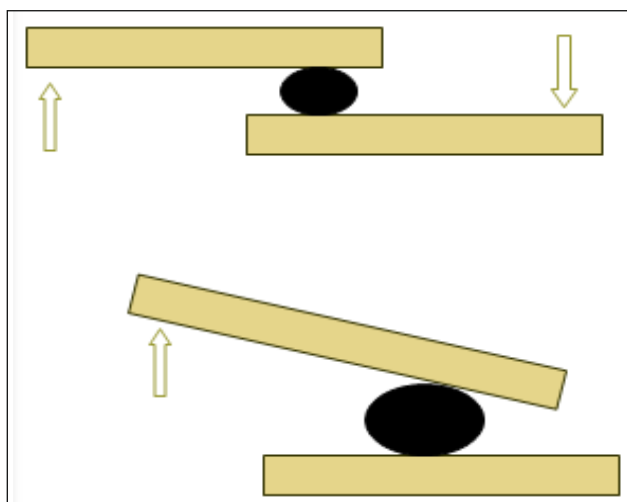

Remark: The directives contained in this documentation are the result of our experiments and of our experience and have been submitted in good faith. Because of the diversity of the materials and substrates and the great number of possible applications which are out of our control, we cannot accept any responsibility for the results obtained. In every case it is recommended to carry out preliminary experiments.



SOUDAFLEX 280

Direct Glazing & Bonding Adhesive

Adhesion/Cohesion/Shear Test:

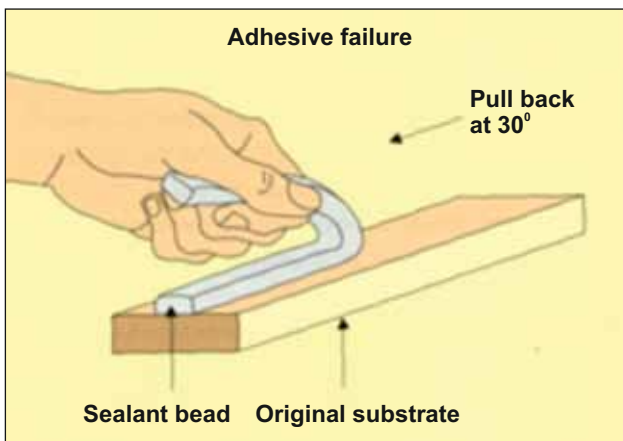
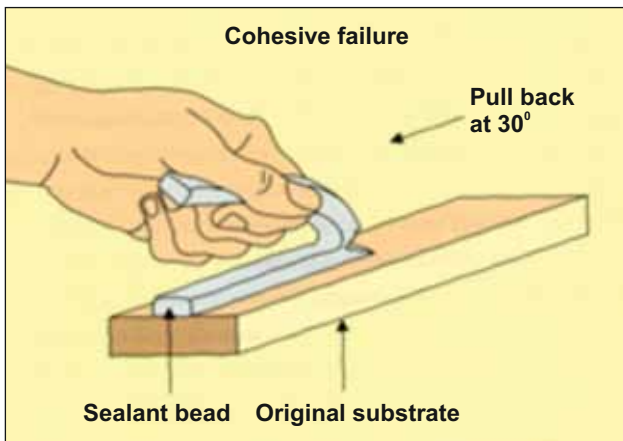
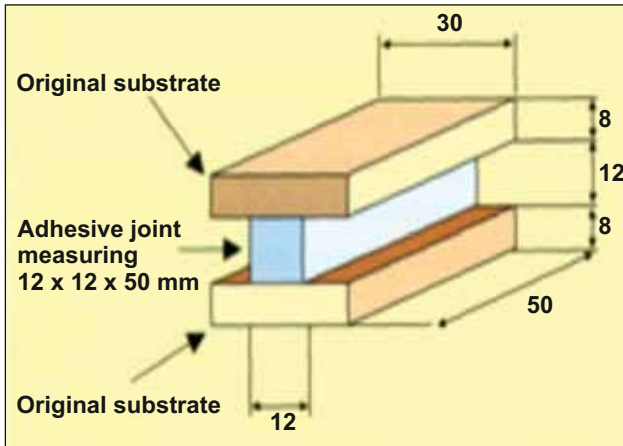

Removal:

Uncured sealant may be removed from tools and equipment, worker hands with McCoy Soudal Swipex.



(A specially designed tissue paper compatible with sealant chemicals and which cleans the sealant 100% without leaving any mark and without damaging painted surface). Contains skin friendly aloe vera & sweet fragrance.

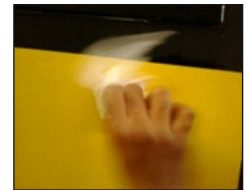

Once cured, the material can only be removed mechanically.



General Information:

The information contained in this technical data sheet is to the best of our knowledge based on our knowledge and experience till date and cannot be used as a guarantee, due to the various different materials present on the market and the fact that the application conditions are not under our direct control and supervision.

McCoy Soudal guarantees constant product quality. McCoy Soudal has the right to modify or up-date this technical data sheet according to requirements. Customers are kindly requested to verify that they are in possession of the latest version.

Always consult the material safety data sheet before using the product.

Remark: The directives contained in this documentation are the result of our experiments and of our experience and have been submitted in good faith. Because of the diversity of the materials and substrates and the great number of possible applications which are out of our control, we cannot accept any responsibility for the results obtained. In every case it is recommended to carry out preliminary experiments.





SEALANT APPLICATION CHECKLIST

To ensure perfect sealing and bonding application, you can use this check list for your internal audit.

Masking:

- Clear the surface with lint free cotton fabric to remove dust.
- Apply masking tape at distance of 1mm from the application area.
- Press the masking tape firmly for better finish.
- Complete the masking-sealant sealing-tooling-de-masking with in 3 hrs.
- Remove masking tape immediately after tooling and before the sealant skins over.
- For better finish use five line sealant masking tape.

Mouth opening:

- Sausage lock- removes this lock completely by cutting it.
- Open sausage/ cartridge just before the application (max.5 minutes before).
- Aluminum cartridge – puncture its mouth with thick round nail/ tool, puncture it with max diameter for the smooth flow of sealant.
- Do not hit the bottom of cartridge to avoid the damage of bottom plunger.

Nozzle cutting:

- Plastic nozzle - cut it as per the groove of filling (in cross direction)
- Adjust the nozzle depth as per the groove, change nozzle if required.(A) Round bead for sealing, (B) triangular bead for glass bonding with base of 10 mm & height of 12-15mm.
- For bead size refer to the table given by McCoy Soudal as per size and weight of component.

Sealing:

- Adjust the pneumatic gun air pressure. (6 Bar).
- Fill the sealant in constant bead.
- Do not over fill or under fill sealant.
- Try to make joint less bead.

Tooling:

- Finish tooling before skin formation.
- Please check skin formation during season variation.
- Do not leave tooling during lunch or day close.

De-masking:

- Remove the masking tape after tooling and finishing.
- Try to complete tape application & removing activity within 3 hrs.
- Avoid hand touch to the body to avoid sealant marks.

Finishing:

- Do finishing in two parts (A)- before de-masking (B) after de-masking.
- Use soapy water solution.
- Avoid excess bubble formation due to soap.

Cleaner & primer:

- Shake the bottles well before use.
- Always keep the mouth of the bottle close and tight, do not leave it open.
- Keep the material in original container for storage, do not change aluminum bottle.
- Take the primer out as and when needed in desired quantity.
- Do not put unused primer back in bottle.
- Keep it away from fire/welding area. Do not smoke, do not drink, do not inhale.
- Use cleaner and give 2-3 minutes to dry it completely.
- Use primer and give 5-10 minutes to dry it completely.

Glass bonding:

- Check the glass & body aperture / frame by just keeping it together for size & its variation (if needed it varies company to company policy & practice).

- Remove paint particles from frame.
- Remove tape spacers from glass.
- Clean both glass & frame perimeter by Soudal Universal Cleaner 165. Cleaning width 50mm, wait for 2-3 minutes till chemical evaporates completely.
- Apply Soudal Universal Primer 175 on the periphery of glass & frame, application width 20 mm. Wait for 5-10 minutes till it dries completely.
- Apply sealant on the frame in V-shape cut nozzle to achieve triangular bead of 10mm base x 12- 15mm height.
- Fix the glass by lifting it with vacuum cup lifter, hold the glass on the spacer, also put small spacer throughout the sealant periphery of sealant to keep it away from the body frame. (spacer shore A-hardness should be 30-45).
- Keep the glass on hold with the help of tape & other support for 4-8 hours minimum.

NOTE IT

- Wash your hands completely before taking food.
- Read the instructions mentioned on the packing carefully.
- Always check the product expiry date before use.
- Read all safety instructions carefully and follow them.
- Keep the product in the original packing.
- For more information refer to material safety data sheet.
- Follow the storage conditions for long lasting life & best use of the material.

Remark: The directives contained in this documentation are the result of our experiments and of our experience and have been submitted in good faith. Because of the diversity of the materials and substrates and the great number of possible applications which are out of our control, we cannot accept any responsibility for the results obtained. In every case it is recommended to carry out preliminary experiments.

