



constructive solutions

Supercast SW

Swellable waterstops for in-situ concrete

Uses

Integral sealing for construction joints in concrete cast in-situ, Convenient and problem solving in situations where a conventional waterstop would require complex shuttering. Typical uses include secant piled and diaphragm walled basements, pile caps and casting against old concrete. The Supercast SW range can provide simple solutions to detailing pipe entries, construction joints in the vertical plane and to kicker joints. They can be linked to Supercast PVC waterstops to give an appropriate effective combination of waterstops which maintain network continuity.

Advantages

- Easy to install by adhesive bonding, masonry nailing or casting into joint faces.
- Supercast SWX enables full integration of Supercast SW and Supercast PVC networks.
- Supercast SW Adhesive can be applied to damp substrates.
- Solves detailing problems in conjunction with Supercast PVC waterstops.
- Swelling properties unaffected by long term wet/dry cycling.
- Tolerant of salts in concrete and groundwater.
- Sustains effective seal in wet conditions.
- Highly adaptable to accommodate complex joint shapes.

Standard compliance

Supercast SW10 and Supercast SW20 Plus are suitable for use in contact with potable water and are Water Byelaws Scheme Approved Products.

Description

The Supercast SW range consists of swellable waterstops; Supercast SW formed sections and Supercast SWX gunapplied paste and Supercast SW adhesive.

A non swellable adhesive, Supercast SW Adhesive enables Supercast SW sections to be positively installed and linked into conventional Supercast PVC waterstop networks.

This allows the use of Supercast PVC for expansion joints and Supercast SW for construction joints whilst maintaining an integrated waterproofing network.

Supercast SW sections are made from high performance synthetic elastomer strips.

Supercast SWX is a grey, elastomeric water-swellable gun applied paste. The swelling action of the Supercast SW range is the result of contact between water and hydrophilic groups which are part of the Supercast SW polymeric structure.

These hydrophilic groups are not subject to extraction or loss of swelling performance by prolonged or repeated wetting.

Expansion of the waterstop creates a positive pressure against the faces of the concrete joint, thus preventing water passing through the protected joint.

Design criteria

Supercast SW should be used to prevent the passage of water through non-movement joints in both new in-situ concrete and between new and existing concrete. Supercast SW increases in volume up to 300% and gives resistance to hydraulic pressure.

Supercast SW10 and SW20 Plus give resistance to a maximum hydraulic head of 50 meters and Supercast SW20 a maximum of 20 meters.

Swelling of Supercast SW in fresh concrete is minimal therefore maximizing the positive pressure seal provided by the hydrophilic to the protected joint.

Supercast SW 10 is suitable for use in new concrete construction where steel reinforcement is continuous through the joint, minimizing the possibility of movement occurring. Supercast SW 20 and Supercast SW20 Plus are suitable for application between existing and newly placed concrete where there is little or no steel continuity and therefore some small movement may occur.

The minimum thickness of concrete cover required to accommodate pressure developed during the swelling process is 70 mm for Supercast SW10 and 100 mm for Supercast SW20 and SW20 Plus.

Supercast SW

Properties

Form	: Rectangular section elastomeric strips
Size	
Supercast SW 10	: 5 mm x 20 mm
Supercast SW 20	: 10 mm x 20 mm
Supercast SW20 Plus	: 10 mm x 20 mm
Solids content	: 100%
Color	
Supercast SW10	: Black
Supercast SW20	: Red
Supercast SW20 Plus	: Black
Unrestrained volumetric expansion ratio	: 300%
Application temperature range	: -5°C to 50°C
Service temperature range	: -30°C to 70°C
Hydrostatic pressure resistance	: Up to 50 meters (refer SW grade)

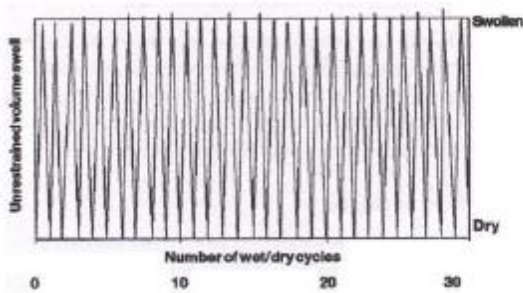

Graphic showing reproducibility of volume swell with wet/dry cycling

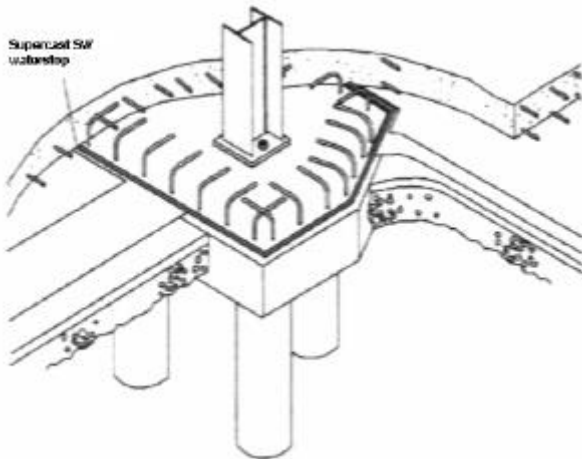

Pile cap detail using Supercast SW waterstop

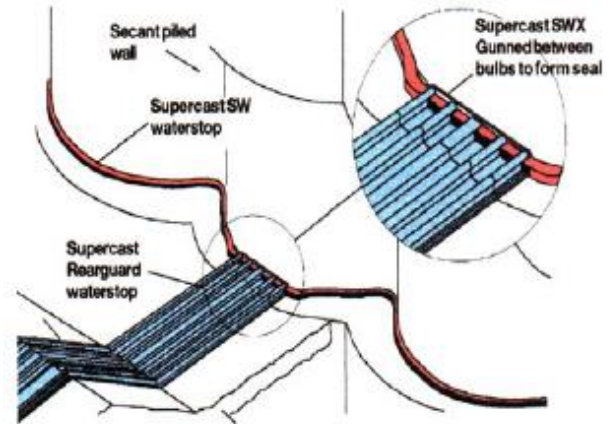

Supercast SW, Supercast SWX and Supercast Rearguard waterstops at secant pile wall and floor slab junction

Specification clauses

Supplier specification

Supercast SW

Water swellable polymeric hydrophilic waterstops (and attachments) where shown on the drawings, shall be Fosroc Supercast SW 10 (or SW 20 or SW20 Plus). It shall be used in accordance with the manufacturer's current application instructions.

Performance specification

Supercast SW

Water swellable polymeric hydrophilic waterstop, where shown on the drawings, shall be made from a preformed elastomeric strip which can integrate into existing waterstop networks. It shall be free from rubber, betonies or other inclusions. The waterstop shall have an unrestrained volumetric expansion of up to 300%. It must not deteriorate under prolonged wet/dry cycling. It must be able to withstand a hydrostatic head of up to 50 meters. It shall be used in accordance with the methods given in the manufacturer's current data sheet.

Application instructions

Supercast SW may be positioned by bonding with Supercast

SWX or Supercast SW Adhesive. The waterstop may be installed either into a groove cast in the concrete or directly onto the concrete surface. Nailing using masonry nails may also be used.

Supercast SW

Limitations

Supercast SW should not be used for expansion joints or those subject to significant repetitive movements.

Supercast SW10 should not be used in the construction of any concrete section of less than 150 mm thickness. Supercast SW20 and SW20 Plus should not be used in the construction of any concrete section of less than 200 mm thickness.

Supercast SW should not be used in locations which allow free unrestrained swelling or for free standing walls, such as bund or dwarf walls, where the swell pressure is sufficient to lift the wall from its foundations. Supercast PVC or SWX of minimum bead diameter 12 mm, should be preferred, dependent on the degree of seal required.

Exposed sections of Supercast SW on site must be protected from water.

Estimating

Pack sizes

Supercast SW 10	: 5 mm x 20 mm x 15 meter rolls
Supercast SW 20 and Supercast SW20 Plus	: 20 mm x 20 mm x 5 meter rolls or 10 mm x 20 mm x 5 meter rolls 10 rolls per carton
Supercast SWX	: 310 ml cartridge packed in cartons of 20
Supercast SW Adhesive	: 380 ml cartridge packed in cartons of 20

Coverage

Supercast SW 10/SW 20	: Usually single run of strip per joint
Supercast SWX	: 6 mm diameter bead minimum 2 to 12 meters run per cartridge depending upon the surface texture of the concrete
Supercast SW Adhesive	: 6 mm diameter bead minimum 2 to 14 meters run per cartridge depending upon the surface texture of the concrete

The above coverages are approximate and make no allowances for wastage.

Storage

Supercast SW

Shelf life	: 12 months
	Store in original unopened cartons or bags in cool, dry conditions, away from sunlight

Supercast SWX

Shelf life	: 9 months
	Store in original unopened cartridges or cartons in cool, dry conditions, away from sunlight

Supercast SW Adhesive

Shelf life	: 12 months
	Store in original unopened cartridges or cartons in cool, dry conditions.

Precautions

Health and safety

Supercast SW

There are no known health hazards associated with Supercast SW 10, Supercast SW 20 and Supercast SW20 Plus in normal use.

Supercast SWX

Supercast SWX may cause sensitisation by skin contact. Avoid contact with skin and eyes. Wear suitable gloves and eye/face protection. Use only in well ventilated areas.

Supercast SW Adhesive

No significant hazard. For additional information see relevant product safety data sheet.

Additional information

Ancillary materials

Supercast SWX

Form	: Elastomeric water swellable paste
Colour	: Grey
Tack-free time	: Approximately 1 hour (20°C / 50% RH)
Cure rate	: 3mm in 24 hours
Volume swell ratio	: 200%
Concrete pour	: 2 to 8 hours

Supercast SW

Supercast SW Adhesive

Form	: Grey paste
Application temperature	: 5°C to 30°C
Maximum open time	: 30 minutes
Concrete pour	: 2 to 8 hours

Adhesion: Can be used on damp concrete provided it is rag dry.

Additional Information

Fosroc manufactures a wide range of complementary products which include:

- waterproofing membranes & waterstops
- joint sealants & filler boards
- cementitious & epoxy grouts
- specialised flooring materials

Fosroc additionally offers a comprehensive package of products specifically designed for the repair and refurbishment of damaged concrete. Fosroc's 'Systematic Approach' to concrete repair features the following:

- hand-placed repair mortars
- spray grade repair mortars
- fluid micro-concretes
- chemically resistant epoxy mortars
- anti-carbonation/anti-chloride protective coatings
- chemical and abrasion resistant coatings

For further information on any of the above, please consult your local Fosroc office.



Fosroc Jordan

Head Office
P.O Box 253,
King Abdullah II Industrial State
Sahab 11512, Jordan
www.fosroc.com

Important note:

Fosroc products are guaranteed against defective materials and manufacture and are sold subject to its standard Conditions for the Supply of Goods and Services, copies of which may be obtained on request. Whilst Fosroc endeavours to ensure that any advice, recommendation, specification of information it may give is accurate and correct, it cannot, because it has no direct or continuous control over where or how its products are applied, accept any liability either directly or indirectly arising from the use of its products, whether or not in accordance with any advice, specification, recommendation of information given by it.

Regional Offices:

Amman-Khalda Offices: Tel: (06) 535 9562
Amman-Sahab Factory: Tel: (06) 402 2665
Aqaba Showroom: Tel: (03) 205 0061

email: enquiryjordan@fosroc.com

Fax: (06) 535 9563
Fax: (06) 402 9475
Fax: (03) 205 0062